

Nautilus™

Seating Capacity.....	7 Adults	
Dimensions	92" x 92" x 36", (234 cm x 234 cm x 91 cm)	
Corner Radius	16" (41 cm)	
Dry Weight.....	885 lbs (402 kg)	
Filled Weight (Average Fill)	3,967 lbs (1,800 kg)	
Water Capacity (Average Fill).....	370 US gallons (1,401 Liters)	
Shipping Weight	885 lbs (402 kg)	
Export Shipping Weight:.....	935 lbs (424 kg)	
Electronic Controls	D1 SmartHUB™ full color glass touch control panel; access to control jets, temperature, settings and maintenance schedule	
Pump 1	North America (60 Hz): 2-Speed, 4.0 HP break, 2.5 HP continuous, 48 Frame	
Export (50 Hz):	1-Speed, 2.0 HP continuous	
Pump 2	North America (60 Hz): 1-Speed, 3.6 HP break, 2.5 HP continuous, 48 Frame	
Export (50 Hz):	1-Speed, 2.0 HP continuous	
Circulation Pump.....	Yes	
Fountain Pump	Yes	
Filtration (factory default)	24/7 Filtration (Purge Cycles 2 x 10 minutes)	
Total VCR Jets	40	
Seat 1 Jets	3 Power Storm Multi Port	
Seat 2 Jets	1 Mini Storm Rotator	
Seat 3 Jets	1 Pillow Mini Storm Rotator, 2 Pillow Cluster Shower Directional, 3 Power Storm Dual Rotator, 4 Mini Storm Directional	
Seat 4 Jets	2 Mini Storm Directional, 2 Mini Storm Rotator	
Seat 5 Jets	1 Pillow Mini Storm Rotator, 2 Pillow Cluster Shower Directional, 4 Power Storm Rotator, 2 Power Storm Directional, 2 Mini Storm Rotator	
Seat 6 Jets	4 Mini Storm Rotator	
Footwell (7).....	1 Typhoon, 2 Mini Storm Directional, 4 Euro Cluster Storm Directional	
Massage Selectors	2	
Special Features	Tactile Therapy, Spa Status Light, 2 Flex Therapy Pillow™, Aux Control	
Water Management System.....	UltraPure™ Plus System; Two 75 ft ³ filter cartridge; 8" Weir	
LED Lighting	Liquid FX™	
Optional	Exterior Lights	
Cabinet Colors	Ashwood, Chestnut, Sandalwood	
Acrylic Colors	Moonstone, UltraLife, Sunstone, Smoked Marble, UltraLife Gray, Desert Stone	
Headrests	4 (2 Standard, 2 Flex Therapy Pillow™)	
Water Feature.....	Fountain with independent flow rate (on or off) adjustment; powered by the fountain pump	
Heater	2.1, 3.4, 5.5 kW	
Export (50Hz)	2.1, 3.4, 5.5 kW	
Electrical Requirements:	North America (60 Hz): 240 VAC@30A, 40A or 50A Export (50 Hz): 230 VAC@1x16A, 1x32A, 2x16A, 3x16A or suitably rated circuit breaker to comply with local electrical codes. Certain countries may require dual power inputs	
Warranty*.....	North America (60 Hz): Lifetime for UltraLife Shell Surface, 7 Years Acrylic Shell Surface, 5 Years Plumbing, 5 Years Equipment and Controls, 7 Years for Terracina™ Cabinet, 1 Year Water Purification System, 2 Years for Jet Insert, 1 Year for Jet Escutcheon, 2 Years Lights, 1 Year Stereo; Export (50 Hz): 10 Years for UltraLife Shell Surface, 7 Years Acrylic Shell Surface, 5 Years Plumbing, 5 Years Equipment and Controls, 2 Years for Terracina™ Cabinet, 1 Year Water Purification System, 2 Years for Jet Insert, 1 Year for Jet Escutcheon, 2 Years Lights, 1 Year Stereo	
Audio System (Optional).....	Fully Integrated Stereo System with Bluetooth capability, 4 premium speakers and a subwoofer	
Optional	SmartTub®	

*(See Warranty Document for Specific Details)

Nautilus

Massage Selector Diagram

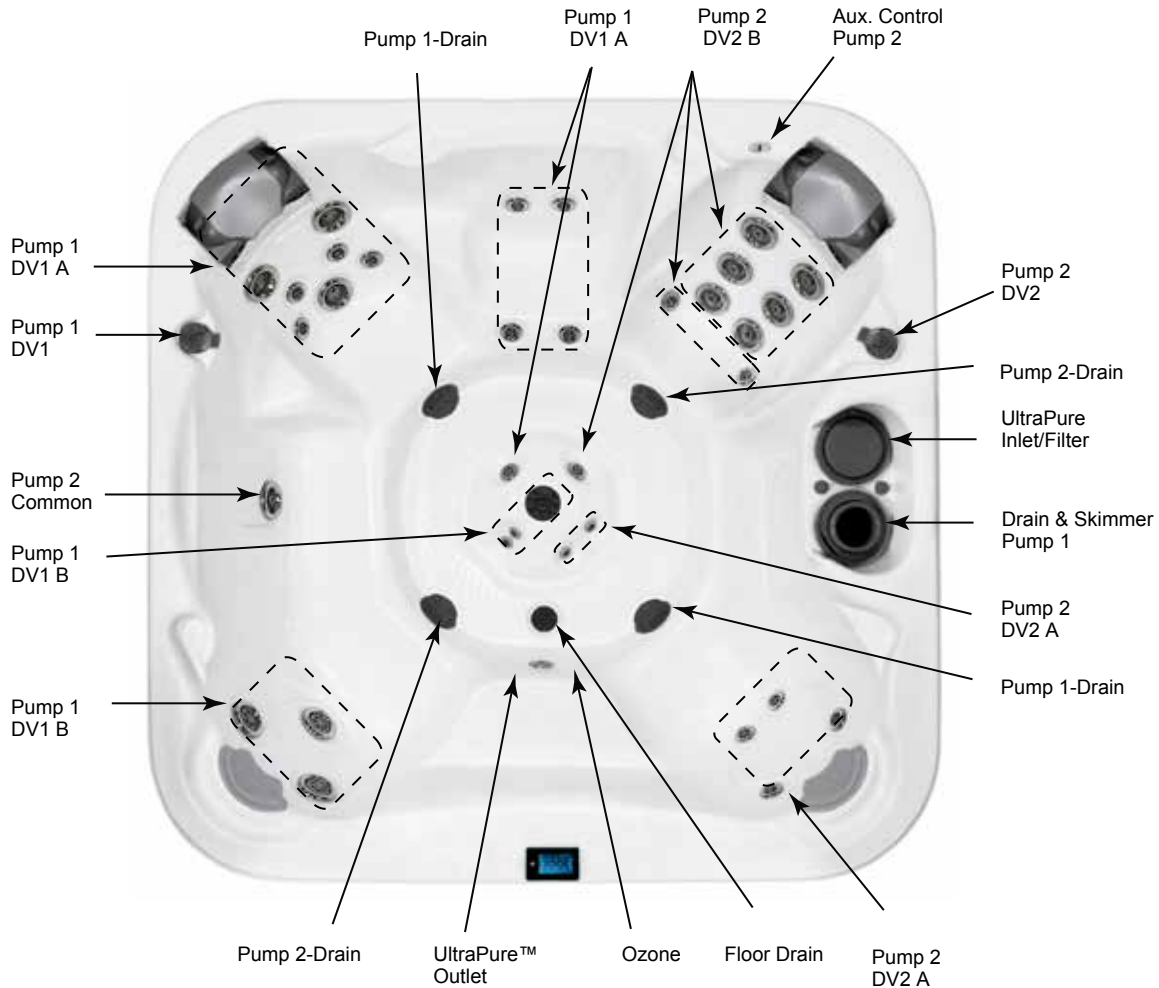

Legend:

- DV1 A = Diverter Valve 1 (A Position Clockwise)
- DV1 B = Diverter Valve 1 (B Position Counter Clockwise)
- DV1 C = Diverter Valve 1 (Neutral Position)
- DV2 A = Diverter Valve 2 (A Position Clockwise)
- DV2 B = Diverter Valve 2 (B Position Counter Clockwise)
- DV2 C = Diverter Valve 2 (Neutral Position)

Spa Operation Subject to Change without Notice

Seat Depths

- 1 = 25.00" (63.50 cm)**
- 2 = 26.00" (66.04 cm)**
- 3 = 26.00" (66.04 cm)**
- 4 = 21.00" (53.34 cm)**
- 5 = 29.00" (73.66 cm)**
- 6 = 27.00" (68.58 cm)**

- 7 = 17.00" (43.18 cm)**
- 8 = 31.00" (78.74 cm)**

Listed dimensions represent distance from top of acrylic to lowest point in seat. **Tolerance ± 0.5" (1.27 cm).**



Dimensions/Specifications are Subject to Change Without Notice

Nautilus

Jet Designation

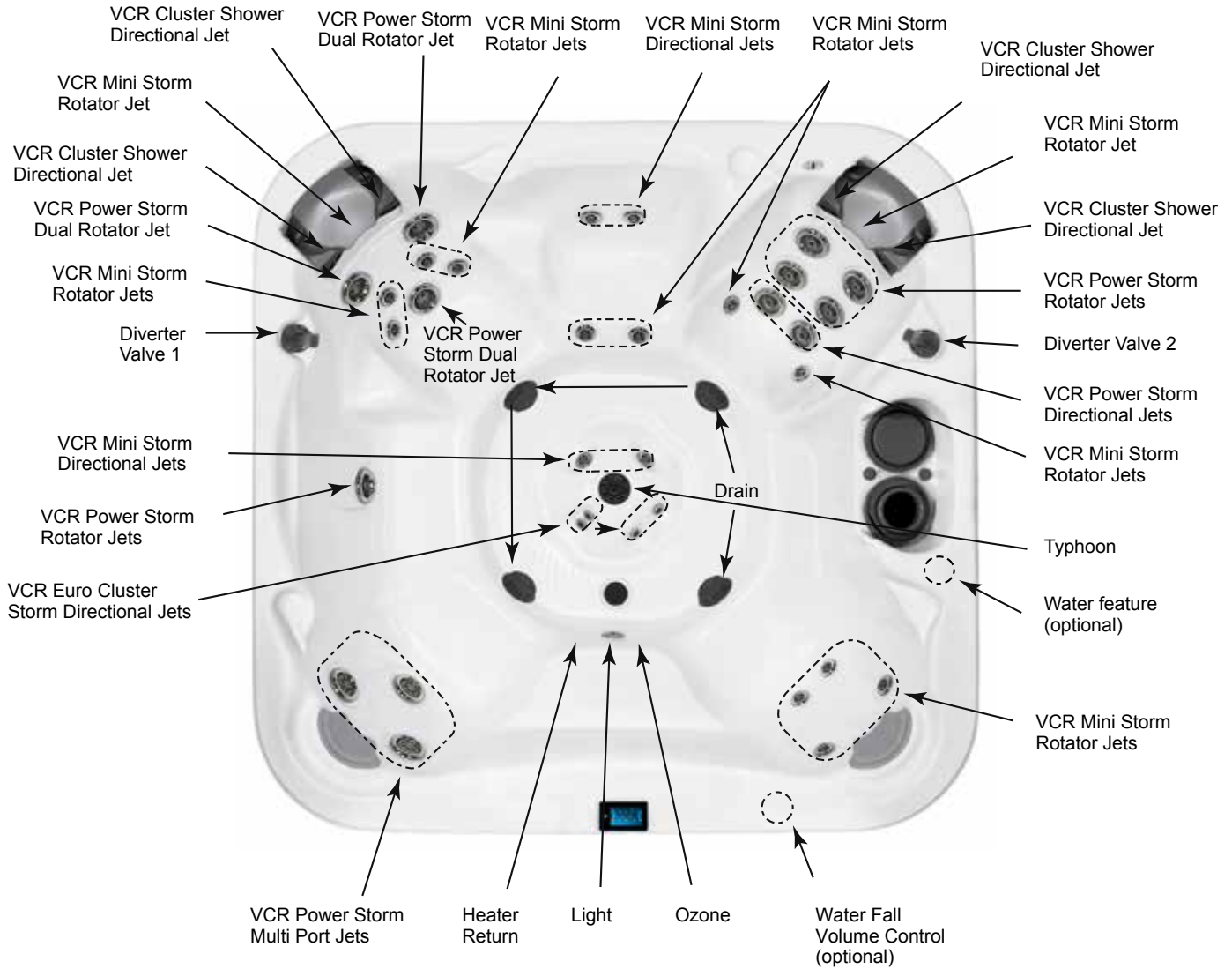

Dimensions/Operation/Specifications are Subject to Change Without Notice

40 Total Jets



Total Jets

Nautilus

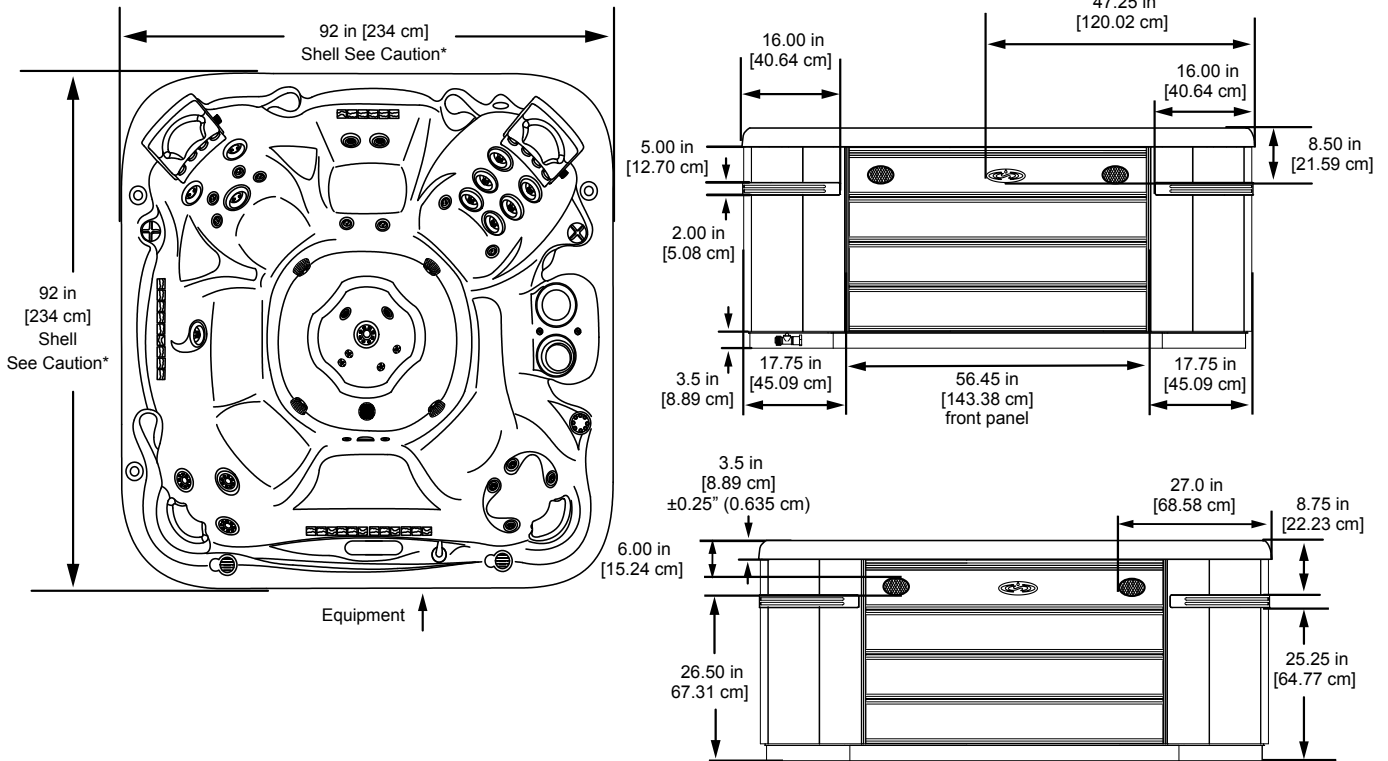

STOP ***Caution:** Due to manufacturing tolerances there could be some minor differences between the actual spa and the drawing above. **If site planning is critical to such tolerances, be sure to measure your actual spa.**

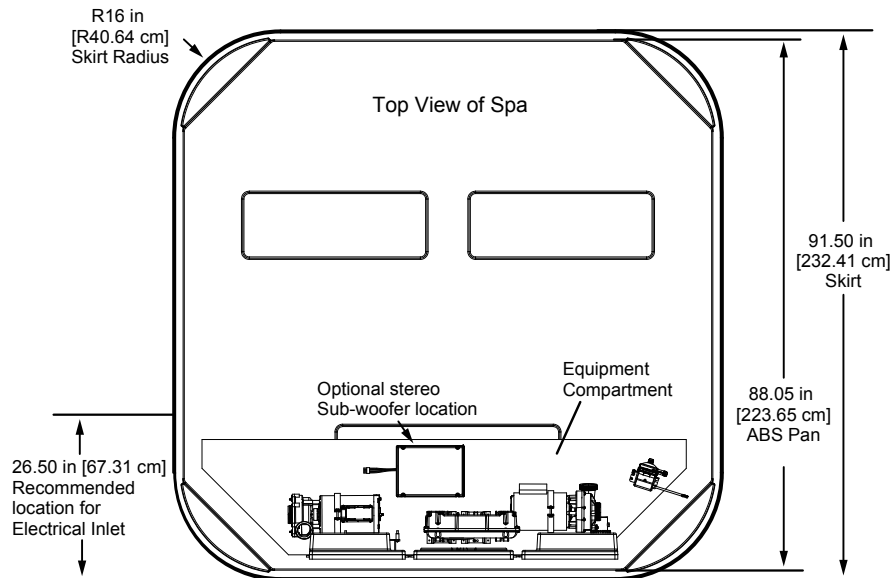

- Note:
1. Subject to change without notice.
 2. Engineering specs may differ slightly from brochure.
 3. For lifter installation allow 18" (45.7cm) clearances on the backside of the spa.
 4. Alternative cabinets may add significant weight. Ask your dealer for exact details.
- Dimensions/Specifications are Subject to Change Without Notice (Tolerance $\pm 0.5"$ [1.27 cm]).